

INVESTIGATIONS ON PHOTOVOLTAIC MODULE SUSTAINED CONTROL OF AC DRIVES UTILIZING MATLAB/SIMULINK

P.Thamizhazhagan

Dr.S.Sutha

Assistant professor, University College of engineering, Panruti, Tamilnadu, India
Assistant Professor [SG], University College of engineering, Dindigul, Tamilnadu, India
thamizhme@gmail.com

Abstract: *The fume of non-Renewable Energy sources has an incredible effect on the era of Electrical Energy. Sun based Energy is continually driving the Renewable Energy Industry because of its plenteous accessibility. Modeling of PV panel is required for looking at the frameworks connected with sun-powered vitality. Two different models are explored for output voltage performance. The composed Photovoltaic Panel is coupled to a Direct Torque Controlled (DTC) inverter-fed permanent magnet synchronous machine (PMSM). The switching the Inverter involves SVPWM. This paper presents the examination investigation of these simulated models for legitimacy and exactness utilizing MATLAB/SIMULINK. The execution elements like Torque and speed of the machine is explored to such an extent that the torque and speed ripples connected with DTC are significantly abridged.*

Keywords: PV Panel, DTC, SVPWM, PMSM

1. INTRODUCTION

Consumption of an outsized quantity of energy during a country indicates the hyperbolic activities in Domestic, Transportation, Agriculture and trade Sectors. The utility electricity sector in India had associate degree put in the capability of 308.83 GW as of thirty November 2016. Out of which 9% is from Solar, wind and tidal of total put in capability [1].

India is that the world's third largest producer and fourth largest shopper of electricity. Concern for the atmosphere as a result of the ever-increasing use of fossil fuels and speedy depletion of natural resources has headed to the development of different sources of renewable energy. In India, the major active part in energy production is through astral and airstream sources [2]

Solar Energy may be a significant supply of power and might be utilized by the electrical phenomenon

conversion systems. Neglecting the opportunity cost of alternative energy and considering merits it may be wide used for Industrial Applications.

The output of the PV panel usually depends on sun irradiation and temperature. The output is reduced in the case of pollutants and climatic conditions. Voltage fed converters receives dc voltage at one aspect and convert it to a voltage on the other aspect. The AC voltage and frequency could also be variable or constant reckoning on the applying. A voltage fed electrical converter ought to have a stiff voltage supply at the input, that is, its Thevenin electrical resistance ought to ideally be zero. An outsized condenser may be connected to the input if the source isn't stiff. The dc voltage could also be mounted or variable and should be obtained from a utility line or rotating a machine through a rectifier and filter. It may also be obtained from battery, cell or star electrical phenomenon array [3-5].

One necessary characteristic of a voltage fed device is that the made-up voltage wave isn't laid low with the load parameters. [4]. In the middle 1980, a sophisticated scalar management technique referred to as direct torsion and flux management (DTC) was introduced for a voltage fed PWM electrical converter drives.

This method was introduced in business merchandise and thus created wide interest. There square measure special options of DTC management that may be summarized No feedback current management, no ancient PWM algorithmic rule is applied, No vector transformation as in vector management and adjustive management Techniques to DTC improves the performance of the system [6].

In a static magnet Synchronous machine, the DC field coil of the rotor is replaced by a static magnet. The benefits square measure elimination of Field copper loss, high power density, low rotor inertia and a lot of sturdy construction of the rotor. The demerits square

measure loss of flexibility of field flux management and potential demagnetization result. The machine has a higher potency than associate degree Induction motor however typically its price is higher, that makes the life cycle price of the drive somewhat lower. Static magnet machines, notably at low-power vary, square measure wide utilized in trade. Recently the interest in their application is growing, notably up to 100Kw.

This paper investigates simpower systems and Simscape models of Photovoltaic Module for inverter fed PMSM Machines. It also investigates the implementation of DTC-SVM Control strategies for PMSM. The output performance of Torque and Speed are investigated for low ripples and better performance.

2. MODELLING OF PHOTOVOLTAIC PANEL

2.1 Solar Cell

Mathematically the IV Characteristic of a solar cell may be given as

$$I = I_{SC} - I_0 \left\{ e^{\frac{V}{V_T}} - 1 \right\} \quad (1)$$

But practically the characteristics of a solar cell can be given as

$$I = I_L - I_0 \left[e^{\left\{ \frac{(V+IR_S)}{V_T} \right\}} - 1 \right] - (V + IR_S)/R_{sh} \quad (2)$$

Where I_L = light generated current,
 I_{sc} = Short circuited current,
 R_s = Series resistance,
 R_{sh} = Shunt resistance.

The photo generated current directly depends on Insolation. Temperature is a major factor to be considered while modeling since it affects the fill factor.

2.2 Simpower Systems Model

The PV Cell is represented with a Diode and shunt and series resistances. Fig.1 shows the equivalent circuit model of a PV Cell. The voltage and current are measured and the model is verified for maximum power. The Photovoltaic current and the diode are modeled separately.

2.3 Simscape Solar Cells Model

The parameters of PV Panel such as Short circuit current, open circuit voltage, Irradiance, Series Resistance are considered for modeling in Simulink. The solar cell in MATLAB needs a PS-Simulink converter for connecting it to power systems. The Solar cell is interconnected according to the range of

output required. The parameters of a solar cell in Simscape can be varied with 5 or 8 parameters accordingly.

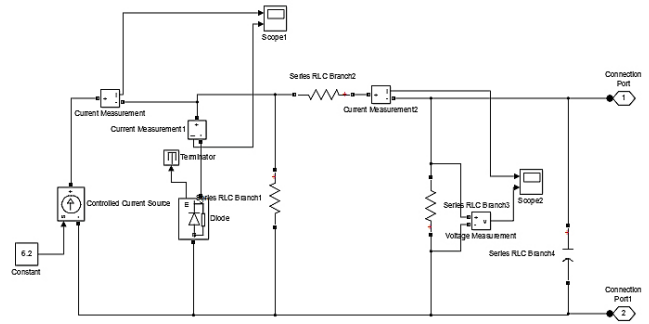

Fig. 1. Simpower system model

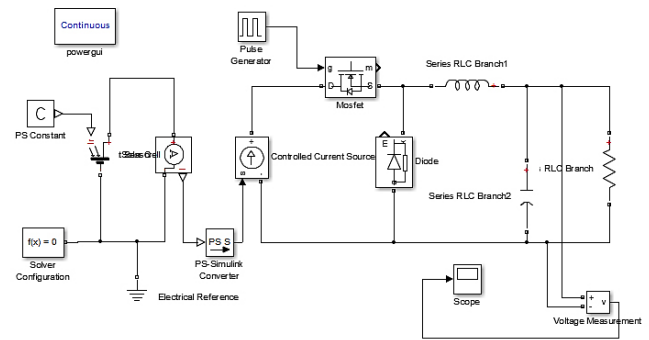

Fig.2 Shows the Simscape model using MATLAB.

3. DRIVE CONTROL

The DC output from the PV Panel is to be regulated with a help of a DC to DC converter. The Zeta Converter has the ability to step up and step down the output voltage irrespective of the polarity of the input voltage. Fig.3 shows the equivalent circuit of a Zeta converter where L_1 and L_2 are inductance that draws current from voltage source V and discharges current during discharging mode.

The output of the rectifier is fed to an Inverter fed PMSM Drive and the switching of the inverter is done with Space vector modulation. The control of Inverter is implemented using DTC a method that directly controls the Torque and flux of the PMSM machine.

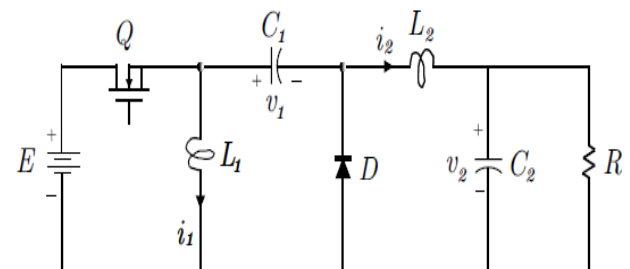

Fig. 3. Zeta converter

4. PMSM MODELLING

Considering a uniform air gap $L_d = L_q$, The PMSM machine can be modeled as

$$T = \frac{3}{2L_s} p |\varphi_s| |\varphi_f| \sin \delta \quad (\text{r})$$

and also with pole saliency, The electromagnetic torque can also be modeled in dq reference frame

$$T = \frac{3}{2} p (\varphi_d i_q - \varphi_q i_d)$$

$$\varphi_s = \int (v_s - i_s R) dt \quad (\text{z})$$

Where R_s is Stator Resistance, L_s is Stator Inductance, φ_d, φ_q and q axis Flux

5. DTC-SVM

The Direct Torque control controls the Torque and flux of the machine and the transformations, reference voltage selection are given in the equation. The DTC-SVM drastically reduces the ripples associated with torque and flux.

$$\begin{pmatrix} u_x \\ u_y \end{pmatrix} = \frac{2}{3} \begin{bmatrix} 1 & -\frac{1}{2} & -\frac{1}{2} \\ 0 & \frac{\sqrt{3}}{2} & -\frac{\sqrt{3}}{2} \end{bmatrix} \begin{pmatrix} u_a \\ u_b \\ u_c \end{pmatrix}$$

$$u_x = \frac{2}{3} [v_a - 0.5(v_b + v_c)]$$

$$u_y = \frac{\sqrt{3}}{3} (v_b + v_c) \quad (\text{e})$$

The space vector representation as

$$u(t) = v_m e^{j\omega t} \quad (\text{f})$$

When the output is sinusoidal, the space vector can be given by $U^* = M e^{j\omega t}$ $0 < M < 1$. The amplitude of the voltage can be controlled by varying the Modulation Index M.

6. SIMULATION RESULTS AND DISCUSSION

6.1 Photovoltaic Module

The Photovoltaic module has been simulated for Simpower systems and Simscape models the outcomes demonstrate that the electrical parameters are very influenced by quality element changes. The open circuit voltage for Simscape model is 44.49 V and for a Simpower system model is 44.5 V. The Short circuit current is 8.19 for Simscape and 8.2 for Simpower system model. The maximum power is

270.2 W for Simscape and 271.1 for Simpower model. The output when compared shows a marginal difference and Fig.4 shows the observations of Simscape and Simpower systems model. With these results the power system module was implemented for the control of PMSM drive.

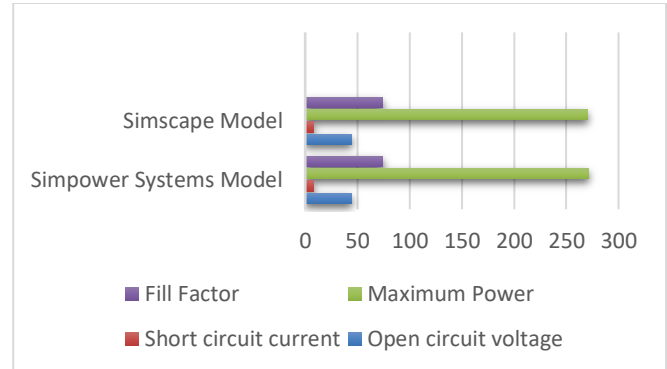

Fig. 4. Observations of Simscape and Sim power System model

6.2 DTC Controlled Drive

The DTC Controlled SVM Drive with $p = 4$ and stator resistance = 0.9587Ω ; flux = 0.1827 Wb, and speed of 2000 rpm. Fig.5 shows the output voltage and current wave forms of PMSM Drive and Fig.6 Shows the torque and speed characteristics of PMSM Drive. The ripples are very much reduced when compared to conventional DTC and DC link voltage associated with Inverter has also been reduced with the help of Photovoltaic module and Zeta converter.

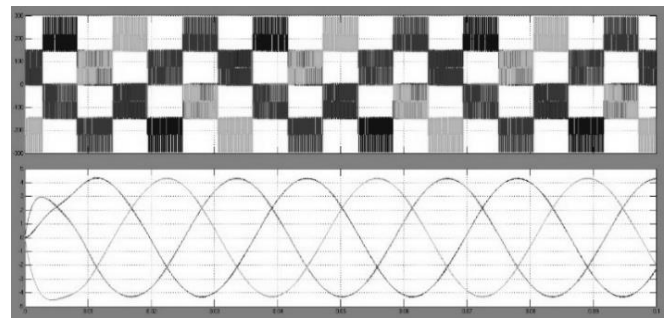

Fig. 5. Output Voltage and current wave forms of PMSM

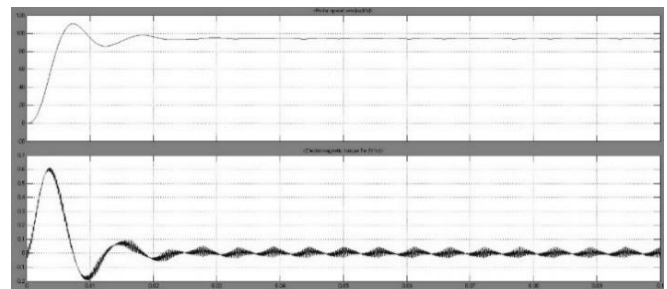

Fig. 6. Speed and Torque wave forms of PMSM

7. CONCLUSION

As the temperature and separation change the yielding power will change. The Simpower systems module construction is found to have better performance but parameter dependence is less compared to Simscape model. In Simscape module even 8 parameters can be utilized for the design of PV Module. The DTC based SVM has given the better performance with reduced ripples in torque. The speed is also controlled and only at low speed, it has some ripples. This can be reduced with the help of implementing some artificial intelligence techniques to the proposed control strategy

REFERENCES

1. GOI., .: *All India Installed Capacity of Utility Power Stations*, Retrieved 19 October 2016.
2. Chandrasekaran., Kaavya, A.: *Executive Summary Power Sector April 2016*, The Economic Times of India. Retrieved 10 June 2016
3. Bimal K Bose.: *Modern Power Electronics and AC Drives*, PHI Learning Pvt limited, New Delhi 2011.
4. Nema,S., Nema,R.K.,Agnihotri,G.: *MATLAB / SIMULINK based study of photovoltaic cells/modules/array and their experimental verification*, International Journal of Energy and Environment, pp.487- 500, Volume 1, Issue 3, 2010.
5. Khaligh, A.,Or, O.C.: *Energy Harvesting: Solar, Wind, and Ocean Energy Conversion Systems*, CRC Press, 2009.
6. Zhong, L., Rahman, M.F., Hu, W.Y., Lim, K.W.: *Analysis of Direct Torque Control in Permanent Magnet Synchronous Motor Drives*, IEEE Transactions on Power Electronics, Vol 12, No.3, May 1997.